



## INNOVATIVE COOLING TECHNOLOGIES FOR SUSTAINABLE DATA CENTER OPERATIONS

Sandeep K Guduru  
USA

*gudurusandeep@gmail.com*

---

### *Abstract*

*The rapid growth of cloud computing, high-performance computing (HPC), and the increase in Internet and social media traffic are all contributing to data centers' increased energy usage and carbon dioxide emissions. In order to solve these issues, this study emphasizes the significance of efficient and sustainable cooling solutions. Conventional air-cooled systems, while widely used, face limitations due to poor thermal properties and high energy demands. The potential for new technologies like liquid cooling, direct fresh-air systems, water-free cooling, and sophisticated. In order to optimize energy and water use while reducing carbon emissions, measures such as Investigations are conducted into the effectiveness of water and power usage. These innovative technologies offer promising pathways to improve the environmental sustainability of data centers. However, achieving these advancements requires continued research and innovation to overcome challenges related to cost, design complexity, and adaptability to diverse operational conditions.*

*Keywords: Data centers, energy efficiency, sustainable cooling, liquid cooling, air-cooled systems, carbon footprint, PUE, WUE, environmental sustainability, advanced cooling technologies.*

### I. INTRODUCTION

The rapid rise of cloud computing and high-performance computing (HPC) has increased interest in data centers' energy usage and carbon impact, as well as the extensive usage of the Internet and social media. The primary components of data centers are electronic equipment used for communication, data processing (servers), and data storage. Since these devices process, store, and transmit digital information, they are collectively referred to as information technology (IT) equipment. To provide consistent, high-quality energy, data centers also commonly use specialized power conversion and backup equipment. Environmental control equipment is also frequently included to ensure the proper humidity and temperature levels for the IT equipment [1]. Typically, data centers are divided into three sections:

- **IT room or data hall:** A lot of heat is produced in a short area by the cables and equipment that are directly linked to the computer and phone systems in the climate-controlled IT room. Additionally, to ensure the integrity and functioning of the technology it holds, a data center must maintain controlled power and cooling conditions since IT equipment is



extremely sensitive to changes in temperature and humidity. As a result, several manufacturers call the IT room "whitespace".

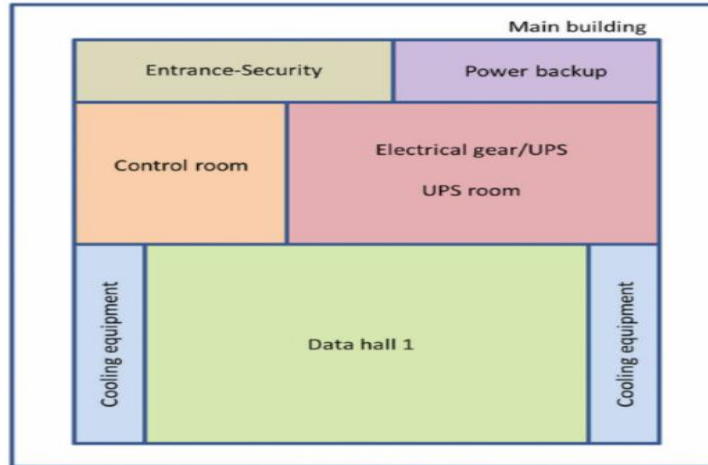

Fig. 1. Scheme of a typical Data Centre layout.

- **Support area:** These are the locations of several systems, including those for cooling, electricity, and telecommunications. These parts basically consist of the electrical equipment, cooling equipment rooms, control room, power backup system, and uninterruptible power supply (UPS) management.
- **Ancillary spaces:** These include places like offices, lobby areas, and bathrooms.

The Advantages of Green Cooling An adequate cooling system is required to remove the heat produced by the nearly complete conversion of electrical power in a data center. The design goals should be the foundation for developing the best cooling system to achieve high reliability, affordability, and energy efficiency. Although most servers are not used at 100% capacity, a cooling system should be designed to withstand the worst-case scenario. During a utility power outage, controlling and anticipating temperature increases is an essential component of cooling system design [2]. To accommodate new IT equipment, the air-cooled systems that serve as the foundation for data center cooling systems have been changing throughout time.

Air-cooled systems are moving towards physical airstream separation within the data center and localized cooling units to handle the rising power densities. However, the utilization of liquid-cooled systems is a new and promising technique for cooling big power-density data centers.

#### A. Structure of the paper

The following is the paper's structure: The main new cooling methods are covered in Section II. Section III provides cooling technology sustainability measures. The current condition of data center cooling is examined in Section IV. A review of the literature is presented in Section V, along with research gaps and recommendations for conclusions and further study in Section VI.



## II. EMERGING COOLING TECHNOLOGIES

Efficient and sustainable cooling technologies are critical for modern data center operations to address the increasing demand for computational power while minimizing environmental impacts. The following are key emerging cooling technologies based on advanced methodologies:

### A. Air-cooled Systems

A pressure vessel known as an air-cooled condenser cools a fluid that circulates inside finned tubes by pushing outside air over the tubes' outside. Car radiators are a typical illustration of an air-cooled condenser. The two main uses for air-cooled heat exchangers are [3]:

- They boost the effectiveness of plants.
- Since they don't require an extra water supply, They work well as an alternative to shell and tube heat exchangers and cooling towers.

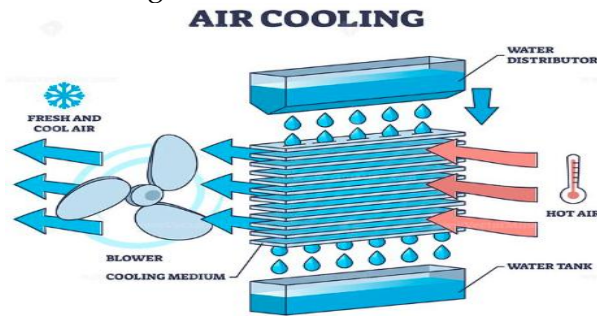

Fig. 2. Air cooling system

### B. Liquid Cooled System

This cooling system cools the battery by using water as a coolant. Because of its practical design and high cooling capacity, liquid cooling is the most often utilized cooling technology. Liquid cooling can be divided into indirect and direct cooling depending on whether the cooling liquid is in contact with the battery, as shown in Figure 3. Indirect liquid cooling usually involves placing heat sinks, separate pipes or enclosures on the surface of the cell [2]. As was already indicated, the main advantage is the higher heat transfer capacity per unit, which allows the processor and coolant to operate with a decreased temperature differential. The wasteful heat-sink-to-air and air-to-coolant heat transfer processes in air-cooled systems are also eliminated by this method. Consequently, the system may have a higher energy efficiency and a lower thermal resistance. It may be possible to reuse heat and do away with active heat rejection devices by raising the input temperature.

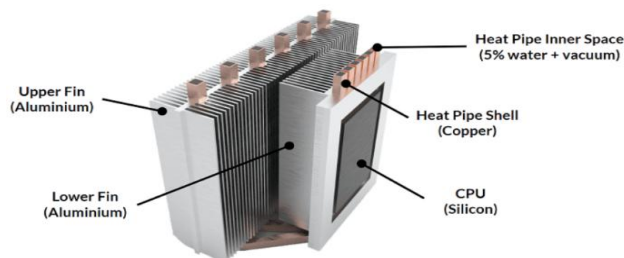

Fig. 3. Liquid cooling of data centers



### C. Direct Fresh-air Cooling System

A Direct Fresh-Air Cooling System is a type of evaporative cooling system where the cooling process involves direct contact between fresh air and the cooling medium. The cooling impact of the water evaporating causes a substance's temperature to drop, a phenomenon known as evaporative cooling (see Figure 4). Latent heat is created as water evaporates, lowering the surrounding temperature and offering beneficial cooling. All it takes to chill a surface effectively is to saturate it and let the water evaporate. A moist surface experiences evaporative cooling as less humid air passes over it; the higher the rate of evaporation, the more cooling occurs. [4].

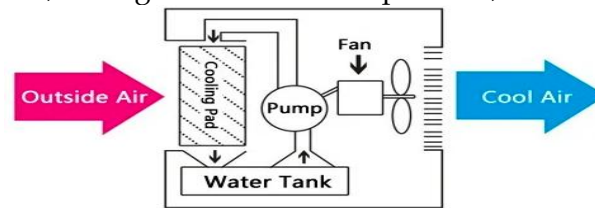

Fig. 4. Evaporative cooling system

### D. Water-Free Cooling System

It is possible to cool a data centre or building using water-based free cooling systems that use cold water and a heat exchanger. It's a type of free cooling system that can reduce or eliminate the need for mechanical refrigeration. As seen in Figure 5, the main difference between a water-based free cooling system and a traditional air conditioning system is that a heat exchanger is built in parallel with the electrical chiller to efficiently use the cooling tower's free cooling capabilities. In other words, the system may operate in three distinct modes due to weather conditions, particularly the temperature of the wet bulb [5]:

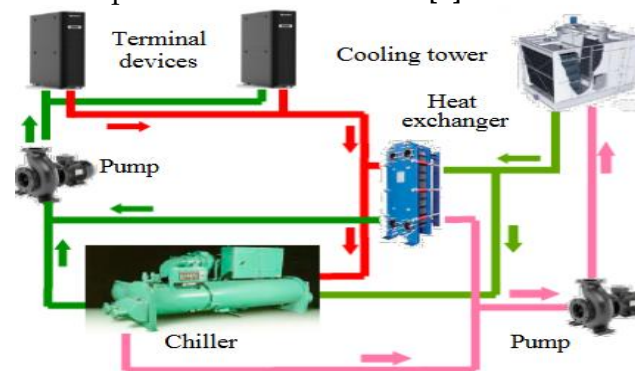

Fig. 5. Water-based free cooling system

- The system may operate in "free cooling" mode when the outside temperature drops (winter) by using the cooling water to switch off the chiller and produce cooling going directly through the water-filled heat exchanger.
- Cooling towers are replaced with chillers, which only regulate condensation heat, and the system runs in "electrical cooling" mode in the summer when the temperature outdoors is high.





- During the spring and fall, when the weather is moderate, the system runs in "free cooling + electrical cooling" mode. This is because the chiller and heat exchanger operate in parallel.

### III. SUSTAINABILITY METRICS FOR COOLING TECHNOLOGIES

Metrics are useful for estimating inefficient processes and determining where improvements can be made, providing information regarding energy cause and water use, as well as carbon emission. According to the provided information, PUE or power consumption metrics that represent the total energy consumed by computing equipment focus on optimizing energy employed by other systems, such as HVAC and power distribution units. Similarly, WUE, for instance, is focused on water conservation related to shortage and data Centre water efficiency. Carbon emission metrics accentuate the necessity for technology that is very energy efficient given the negative impact on the environment that energy consumption brings. All these disparate metrics serve to provide a comprehensive metric metrics framework to improve and optimize cooling operations while supporting sustainability.

#### A. Power Usage Effectiveness (PUE)

To determine a data center's PUE, divide its overall power consumption ( $P_t$ ) by the power used by its computer servers ( $P_s$ ) [22], i.e.,

$$PUE = P_t / P_s \quad (1)$$

The non-computer systems in a data center provide an explanation of the difference between  $P_t$  and  $P_s$ . HVAC systems' electricity consumption and power losses caused by This include ineffective electrical distribution system components as well as the electrical impedance of current-carrying wires.[6] ATS, UPS devices, transformers, switchboards, and Power Distribution Units (PDU) are typically included in this system.

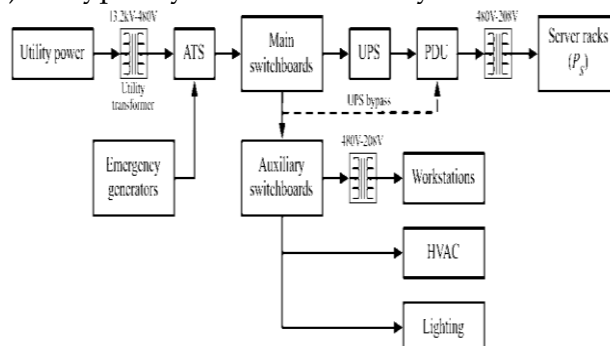

Fig. 6. An example power flow diagram for a data center.

Figure 6 provides a clearer illustration of power conversions and the reasons for losses and inefficiencies by displaying an example data center power flow diagram. If the entire quantity of electricity received by the data center is equal to the power usage of the servers,  $PUE = 1$  then. A PUE of 1 is seen as an indication of a 100% power-usage-efficient data center, as housing these servers is the main function of a data center. Furthermore, it is not possible to have a PUE of less than one.



### B. Water Usage Effectiveness (WUE)

The WUE idea has been expanded to include frameworks for water management, sustainable development, and environmental sustainability. Table I summarises the many ways that WUE is interpreted in the agricultural, industrial, and service sectors, among other water users. So, water-related activities aim towards different WUE goals. However, WUE has only been mentioned in a small number of frameworks as a substitute for conservation and water protection [7].

- **Approaches to Achieve WUE:** The idea of WUE has an impact on water literacy, specifically WUE knowledge because it encompasses a variety of definitions, methodologies, and indicators. It refers to how different water users understand and use WUE. To attain WUE, there are several methods accessible. The most significant techniques that make reference to WUE are those that are based on specific objectives. Producers utilize water more effectively as a result of efforts to expand current output, maximize profits, and minimize expenses. Consumer or regulatory demands for cleaner manufacturing, a smaller water impact, and a circular economy may also serve as motivators.

### C. Carbon Emission Reduction

A key factor in increasing energy efficiency and lowering CE is the development of E&M efficient technologies. In order to target the Iron and Steel (IS) business, this technical innovation in E&M is necessary for recycling materials, using efficient fuels, and using alternative energy supplies with minimal CE. CE is projected using a number of scenarios, with a reduction potential ranging from 12.5% to 63%. One important component of reducing CE is making the most of sustainable energy resources [8]. The utilization of these energy supplies must be optimized, though, because they are either more costly or have other difficult problems. Greenhouse gas emissions during manufacturing are enormous, and the demand for power is always rising.

## IV. CURRENT STATE OF DATA CENTER COOLING

Air conditioning, sometimes referred to as CRAH or CRAC, is the conventional technique for cooling data centers. Floor elevation in a data center with air conditioning. Cold and warm air streams may travel through the server racks since they are arranged back-to-back and face-to-face. The floor has air outlets where chilled air enters and exits the space through the cold stream corridor. The cold air passes through the server rack and emerges at the rear as a stream of hot air, cooling the electronic equipment. The air conditioner then uses cold water to cool the hot air. There are several issues with the traditional air-cooling method, as is widely acknowledged in the literature [9].

- Air has a low convection heat transfer coefficient because of its weak thermal characteristics. There is a noticeable temperature difference as a result of the server rack's poor heat transfer coefficient and the air's significant temperature increase brought on by its low specific heat. This temperature differential, for instance, can be as much as 30°C.



- A localized hot spot on the server might cause the temperature to rise to a rather high level in some places. To properly cool these hot regions, the temperature of the chilled air must be adjusted too low to avoid going over the acceptable temperature limit for the electronic equipment. Because of these different heat loads, the server room is overcooled, while the IT equipment may not be cool enough in other places.
- Even in frigid climates throughout the winter, the refrigeration system must function constantly and in all external temperature circumstances.
- The server room's air absorbs the heat produced by IT equipment and then indirectly removes it.

#### A. Traditional Cooling Methods

The removal of high heat flux from high-tech electronic equipment is still extremely difficult and insufficient despite recent great advancements in electronic cooling systems. [10]. This article provides a summary of the many traditional cooling techniques, their classifications according to the coolants and heat transfer processes, and their cooling efficacy. Cooling modes may be divided into four broad types based on the efficiency of heat transmission, which are:

- Radiation and free convection,
- Forced air-cooling,
- Forced liquid cooling,
- Liquid evaporation.

#### V. LITERATURE OF REVIEW

In this section, they provide some earlier studies on Innovative Cooling Technologies for Eco-Friendly Data Centre Operations.

In, Mohamed, El-Gorashi and Elmirghani (2017) seeks to quantify how various data center networking topologies affect the efficiency and performance of MapReduce shuffle processes. In a variety of data center architectures, including electrical, hybrid, and all-optical switching, the shuffling is optimized using MILP models to maximize throughput and minimize power consumption. Additionally, they show that, in comparison to electronic switching data centers, optical-based data centers may reduce energy usage by an average of 54% while maintaining equivalent performance [11].

In, Shao, Wu and Chen (2014) conducts research and design for a MAS control system based on a ship's electric power plant's central cooling system. The cooling system's design and composition are used to create an experimental table, and the experiment confirms the need for control. The foundation for future research on the MAS control of the intricate cooling system is laid by this study [12].

In, Visessonchok, Sasaki and Sakata (2014) tropical nations like Thailand, a comprehensive citation-based method using academic and patent data is used to identify new green construction technology. Simultaneous analysis of data from patents and scholarly publications has revealed solar cooling to be a viable technique. Given that about 50% of Thailand's energy



usage is related to air conditioning, where there is an abundance of sunlight throughout the year, solar cooling has a lot of promise [13].

In, Choi et al. (2016) examines the thermal characteristics and cooling capacity of a GdBCO magnet cooled using a combined cryogen cooling system that combines solid nitrogen with a small amount of liquid neon. The test findings suggest that the NI GdBCO magnet might be employed in a combined cryogen cooling system to facilitate future reliable portable superconducting applications. The peak temperatures of the magnet were considerably lower when cooled by the mixed cryogen than when cooled by solid nitrogen alone in several heating tests conducted at 26 K[14].

In, Krok (2018) The findings obtained show that using a hybrid cooling system significantly increases the allowed excitation current density when compared to the methods currently utilized to operate turbo generators. The study presents a new hybrid cooling method for the excitation winding of a turbogenerator. Combining the popular axial and radial-axial technologies has greatly improved cooling efficiency [15].

In, Butt, Prabel and Aschemann (2014) presented a novel car engine cooling system using a nonlinear control method. Unfortunately, because of the physical limitations on saturation, the servo-controlled bypass valve and driven coolant pump can be used as control inputs because of the bypass valve's limited opening section and maximum pump volume flow. A discrete-time sampling technique is used in conjunction with a limited sample time to create the multi-variable control. An extended Kalman filter that calculates the system's unknown heat fluxes[16].

The comparative Table I summarizes the provided literature on innovative cooling technologies for sustainable data center operations. This table consolidates the focus areas and key findings of each referenced paper for a clear comparative understanding of their contributions to cooling technologies.

Table I. Literature of Review on Innovative Cooling Technologies for Sustainable Data Center Operations

Reference	Key Topic	Focus Area	Findings/Insights
[11]	Energy efficiency and the effects of networking topologies	MILP models for data center topology optimization of shuffling activities	Comparing optical-based data centers to electrical switching data centers, the former may reduce energy usage by an average of 54%.
[12]	MAS control system for central cooling in electric propulsion	Experimental setup for MAS control in a ship's central cooling system	Research establishes the foundation for applying MAS control to complex cooling systems.
[13]	Detection of emerging green cooling technologies	Analysis of academic and patent data to identify cooling technologies for tropical regions	Solar cooling is identified as promising for tropical regions like Thailand, where air conditioning uses ~50% of total electricity.
[14]	A technique of	Performance of cooling	In repeated heating experiments, a





	mixed cryogen cooling for superconducting magnets	and thermal properties of a GdBCO magnet	mixed cryogen cooling system lowers peak temperatures, demonstrating viability for next-generation portable applications.
[15]	Hybrid cooling system for turbo generators	Integrating axial and radial-axial cooling systems	Significant enhancement over present systems in terms of allowable excitation current density and cooling efficiency.
[16]	Nonlinear control for vehicle engine cooling systems	using a powered coolant pump and a servo-controlled bypass valve to regulate many factors	The nonlinear controller approach achieves better control under physical limitations using A Kalman Filter in Discrete Time.

## VI. CONCLUSION AND FUTURE WORK

This review highlights the growing importance of energy efficiency and sustainable cooling technologies in data centers to address the escalating demand for computational power and mitigate environmental impacts. Traditional air-cooled systems are limited by poor thermal properties and inefficiencies, leading to the evolution of advanced cooling methods such as liquid-cooled systems, direct fresh-air cooling, and water-free cooling systems. Together with sustainability power use effectiveness (PUE) and water usage effectiveness (WUE) measurements, these innovative technologies offer a way to maximize energy and resource use while reducing carbon emissions. Modern data centers must balance performance, affordability, and environmental sustainability, as seen by the move toward creative cooling systems.

In order to monitor and optimize vigor and cooling proficiency in real time, developing integrated cooling methods that make use of AI and ML should be the main goal of future research. Data centers' carbon footprint may be further decreased by investigating energy recovery technologies and the incorporation of renewable energy. Additionally, expanding the use of liquid cooling and hybrid systems to accommodate higher densities while ensuring scalability and reliability will be crucial. Collaborative efforts between industries and policymakers are needed to establish standards and incentives that encourage the adoption of sustainable cooling technologies globally.

## REFERENCES

1. E. Oró and J. Salom, "Data centre overview," *Adv. Concepts Renew. Energy Supply Data Centres English*, pp. 1–26, 2017, doi: 10.1201/9781003336990-1.
2. A. Capozzoli and G. Primiceri, "Cooling systems in data centers: State of art and emerging technologies," *Energy Procedia*, vol. 83, pp. 484–493, 2015, doi: 10.1016/j.egypro.2015.12.168.
3. M. Baweja and V. N. Bartaria, "A Review on Performance Analysis of Air-Cooled Condenser under Various Atmospheric Conditions," *Int. J. Mod. Eng. Res.*, vol. 3, no. 1, pp. 411–414, 2013.
4. S. V Mehere, K. P. Mudafale, and S. V Prayagi, "Review of Direct Evaporative Cooling System With Its Applications," *Int. J. Eng. Res. Gen. Sci.*, 2014.



5. Y. Zhang, Z. Wei, and M. Zhang, "Free cooling technologies for data centers: Energy saving mechanism and applications," *Energy Procedia*, vol. 143, pp. 410–415, 2017, doi: 10.1016/j.egypro.2017.12.703.
6. J. Yuventi and R. Mehdizadeh, "A critical analysis of Power Usage Effectiveness and its use in communicating data center energy consumption," *Energy Build.*, vol. 64, pp. 90–94, 2013, doi: 10.1016/j.enbuild.2013.04.015.
7. M. Patterson, D. Azevedo, C. Belady, and J. Pouchet, *Water usage effectiveness (WUE): a Green Grid data center sustainability metric*. 2011.
8. R. K. Sinha and N. D. Chaturvedi, "A review on carbon emission reduction in industries and planning emission limits," *Renew. Sustain. Energy Rev.*, vol. 114, no. July, p. 109304, 2019, doi: 10.1016/j.rser.2019.109304.
9. Z. Li and S. G. Kandlikar, "Current status and future trends in data-center cooling technologies," *Heat Transf. Eng.*, vol. 36, no. 6, pp. 523–538, 2015, doi: 10.1080/01457632.2014.939032.
10. S. M. Sohel Murshed and C. A. Nieto de Castro, "A critical review of traditional and emerging techniques and fluids for electronics cooling," *Renew. Sustain. Energy Rev.*, vol. 78, pp. 821–833, 2017, doi: 10.1016/j.rser.2017.04.112.
11. S. H. Mohamed, T. E. H. El-Gorashi, and J. M. H. Elmirghani, "On the energy efficiency of MapReduce shuffling operations in data centers," in *International Conference on Transparent Optical Networks*, 2017. doi: 10.1109/ICTON.2017.8024733.
12. Y. Shao, Y. Wu, and Y. Chen, "Design and research of Multi-Agent Control system for central cooling system," in *CCIS 2014 - Proceedings of 2014 IEEE 3rd International Conference on Cloud Computing and Intelligence Systems*, 2014. doi: 10.1109/CCIS.2014.7175732.
13. T. Visessonchok, H. Sasaki, and I. Sakata, "Detection and introduction of emerging technologies for green buildings in Thailand," in *Proceedings of PICMET '14 Conference: Portland International Center for Management of Engineering and Technology; Infrastructure and Service Integration*, 2014, pp. 620–631.
14. Y. H. Choi et al., "Cooling Performance and Thermal Characteristics of No-Insulation GdBCO Magnet Cooled by a Mixed Cryogen Cooling System," *IEEE Trans. Appl. Supercond.*, vol. 26, no. 4, pp. 1–5, 2016, doi: 10.1109/TASC.2016.2527636.
15. R. Krok, "Assessment of thermal condition of turbogenerator's excitation winding with new hybrid cooling system," in *2018 International Symposium on Electrical Machines, SME 2018*, 2018. doi: 10.1109/ISEM.2018.8442428.
16. S. S. Butt, R. Prabel, and H. Aschemann, "Input-output linearisation with input constraints for an innovative engine cooling system," in *2014 European Control Conference, ECC 2014*, 2014. doi: 10.1109/ECC.2014.6862392.